

## Engineered Nanoparticle Electronic and Photonic Device Materials

NSF NIRT Grant 0103543

PIs: H.A. Atwater, R.C. Flagan, L.D. Bell, M.L. Green (Agere), G. Bourianoff (Intel)  
California Institute of Technology

In the mesoscopic size regime, semiconductor materials have size-tunable properties that are intermediate between those of single atoms and their corresponding bulk solids. We are studying optical and transport properties of group IV semiconductor (Si and Ge) nanocrystals that behave electronically as 'quantum dots'. We have also begun under this NIRT program a study of plasmon-mediated electromagnetic coupling in arrays of metal nanocrystals.

### 1. Nanocrystal Memory Devices

Floating gate field effect devices are the basis of today's nonvolatile memory technology, such as the "flash" memory chips that are the 'film' in electronic cameras and the data storage media for other portable electronic devices. Current floating gate memory designs suffer from clear performance limits. Our research effort in nanocrystal memories is aimed at overcoming these present performance hurdles by use of floating gate comprised of a dense array of silicon nanocrystals. Recently we have fabricated state-of-the-art nanocrystal floating gate nonvolatile memory devices, using a novel aerosol synthesis process for floating gate formation.

### 2. Optically Addressed Nanocrystal Memories

We are investigating fundamental issues of the relationship between nanocrystal charge state and photoluminescence characteristics. This effort utilizes an 'optical nanocrystal memory' shown in Figs. 1 and 2 to probe the charge-state dependence of the photoluminescence of nanocrystals. To date, we have seen evidence of a strong field-induced modulation of nanocrystal photoluminescence, as shown in Fig. 3, suggesting that this mechanism may enable high-speed optical readout of the voltage state of the gate.

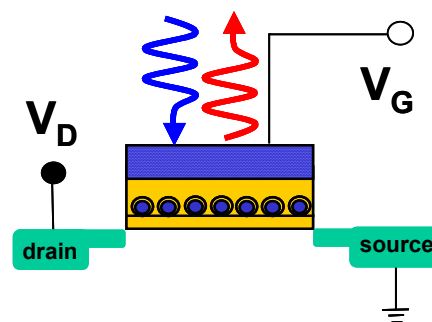

**Fig. 1.** Schematic of silicon optical nanocrystal memory device. An optically transparent doped polysilicon gate contact modulates the electric field in a dense array of silicon nanocrystals embedded in the gate oxide, switching the near-infrared photoluminescence.



**Fig. 2.** Photograph of nanocrystal memory devices fabricated in collaboration with Intel Corporation on 300 mm substrates in a conventional silicon ultralarge scale integrated (ULSI) process.

### 3. Layered Tunneling Barriers

Layered heterostructure tunneling barriers using novel high k-dielectric materials may hold the key to realization of Si-compatible tunneling dielectrics for floating gate nonvolatile memories that have both nano-second regime program/erase times and truly archival charge retention characteristics. The trade off between program and erase time and charge retention is currently the largest performance obstacle in floating gate memory devices.

### 4. Plasmonics: Nanoparticle Chain Arrays Break Through the Diffraction Limit for Optical Devices

Since development of the light microscope in the 16<sup>th</sup> century, optical device performance has been limited by diffraction. Optoelectronic devices of today are more than an order of magnitude bigger than state-of-the-art electronic devices for this reason. The NIRT investigators began a new research effort under this grant that has shown that by circumventing the diffraction limit it is possible to design “plasmonic” optoelectronic device components with spatial confinement of light at dimensions less than 10% of the wavelength size. Thus there is no fundamental scaling limit to the size and density of optoelectronic devices, and ongoing work is aimed identifying important device performance criteria in the subwavelength size regime. Ultimately this research direction may yield a whole class of subwavelength-scale optoelectronic components (waveguides, sources, detectors, modulators) that could form the cornerstone of optical devices that are scaleable to molecular

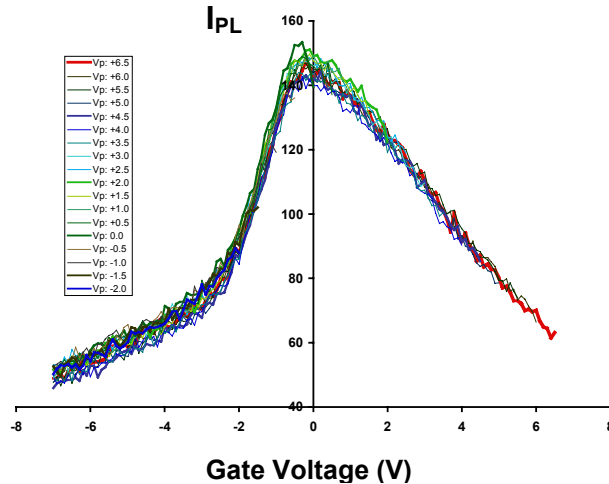

**Fig. 3.** Photoluminescence intensity variation with applied gate voltage, for various program and erase states of the memory device. The independence of the photoluminescence intensity from the program state indicates a field-induced rather than charge injection-induced intensity modulation.

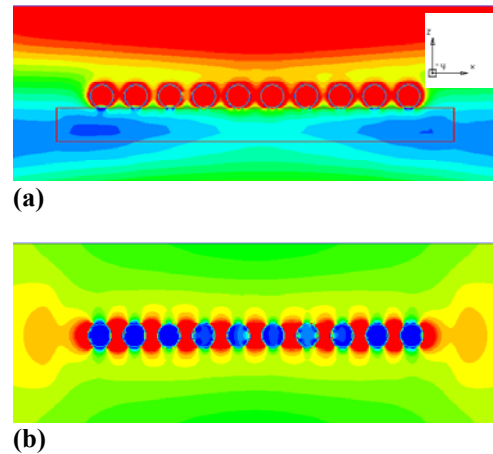

**Fig. 4.** Finite difference time domain (FDTD) calculations of illustrating spatial nanometer-scale spatial confinement of light at 590 nm wavelength in plasmon waveguides composed of 50 nm Au particles. In (a) cross-section view and in (b) plan view of longitudinal mode excited resonantly at the plasmon frequency.

dimensions, with potential imaging, spectroscopy and interconnection applications in computing, communication and chemical/biological detection.

Such plasmonic devices exploit the dipole-dipole coupling at the plasmon frequency between nanoscale metal particles in particle chain arrays, and the dispersion relations for structure exhibit the tendency for electromagnetic excitations to "hop" between electric dipoles. Light can even propagate around sharp corners and through nanoscale networks -- all of which are impossible in conventional optical waveguides.

### References:

#### "Plasmonics - A Route To Nanoscale Optical Devices"

Maier SA, Brongersma ML, Kik PG, Meltzer S, Requicha AAG, Atwater HA *Advanced Materials* **13** 1501 (2001).

#### "Observation of coupled plasmon-polariton modes in Au nanoparticle chain waveguides of different lengths: Estimation of waveguide loss"

Stefan A. Maier, Pieter G. Kik, and Harry A. Atwater *Applied Physics Letters*, **81** 1714 (2002).

#### "Models For Quantitative Charge Imaging By Atomic Force Microscopy"

Boer EA, Bell LD, Brongersma ML, Atwater HA *J. Applied Phys.* **90** 2764 (2001).

#### "Localized Charge Injection In SiO<sub>2</sub> Films Containing Silicon Nanocrystals"

Boer EA, Brongersma ML, Atwater HA, Flagan RC, Bell LD *Appl. Phys. Lett.* **79** 791(2001).

#### "Synthesis And Characterization Of Aerosol Silicon Nanocrystal Nonvolatile Floating-Gate Memory Devices"

Ostraat ML, De Blauwe JW, Green ML, Bell LD, Brongersma ML, Casperson J, Flagan RC, Atwater HA *Appl. Phys. Lett.* **79** 433 (2001).

#### "Charging Of Single Si Nanocrystals By Atomic Force Microscopy"

Boer EA, Bell LD, Brongersma ML, Atwater HA, Ostraat ML, Flagan RC *Appl. Phys. Lett.* **783** 133-3135 (2001).

"Materials issues for layered tunnel barrier structures", J.D. Casperson, L.D. Bell, Harry A. Atwater, J. *Appl. Phys.*, **92** 267 (2002)

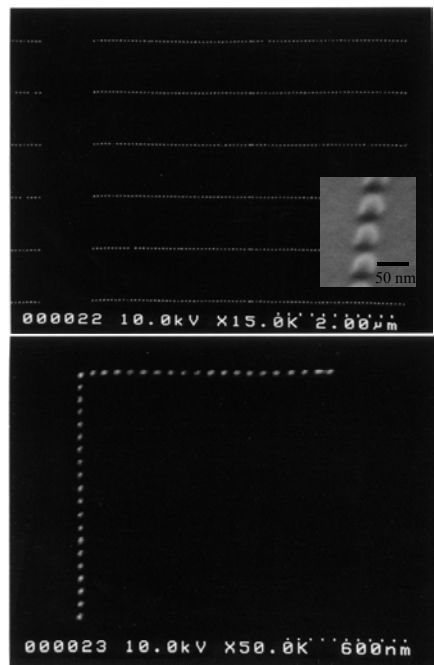

**Fig. 5.** Scanning electron microscope images of plasmon waveguides, and 90 degree bend waveguide fabricated using electron beam lithography. The gold dots are 50 nm in diameter and spaced by 75 nm (center-to-center).

