



---

# The Interdependence of Family Members: Approaches in Multilevel Modeling

Aline G. Sayer, JuliAnna Z. Smith, Jade N. Logan  
Center for Research on Families,  
University of Massachusetts Amherst  
NCFR 2008



# Research questions in family research

---

- Questions often explore relationships between family members
  - Do mothers and fathers have similar or discrepant views of parenting?
  - Are mother-child interactions reciprocal or antagonistic?
- Relationship attributes such as discrepancy, mutuality, reciprocity, compensation are properties of the dyad, not of the individuals alone
- Measuring these attributes can present problems in the application of traditional statistical approaches such as regression or ANOVA



# Key Points

---

- Nonindependence
  - conceptual and statistical issues
  
- Data have a hierarchical structure
  - Variation within and between dyads
  
- Design considerations
  - Same outcome for both members of dyad
  - Types of dyads



# Definition of non-independence

---

Degree of greater similarity between linked observations versus unlinked observations

Nonindependence as the *correlation* between linked observations

- | Estimated as the intraclass correlation
- | Sometimes interpreted as the amount of variance in the outcomes that is attributable to differences across (or between) dyads

# Linked outcomes within-dyad

---

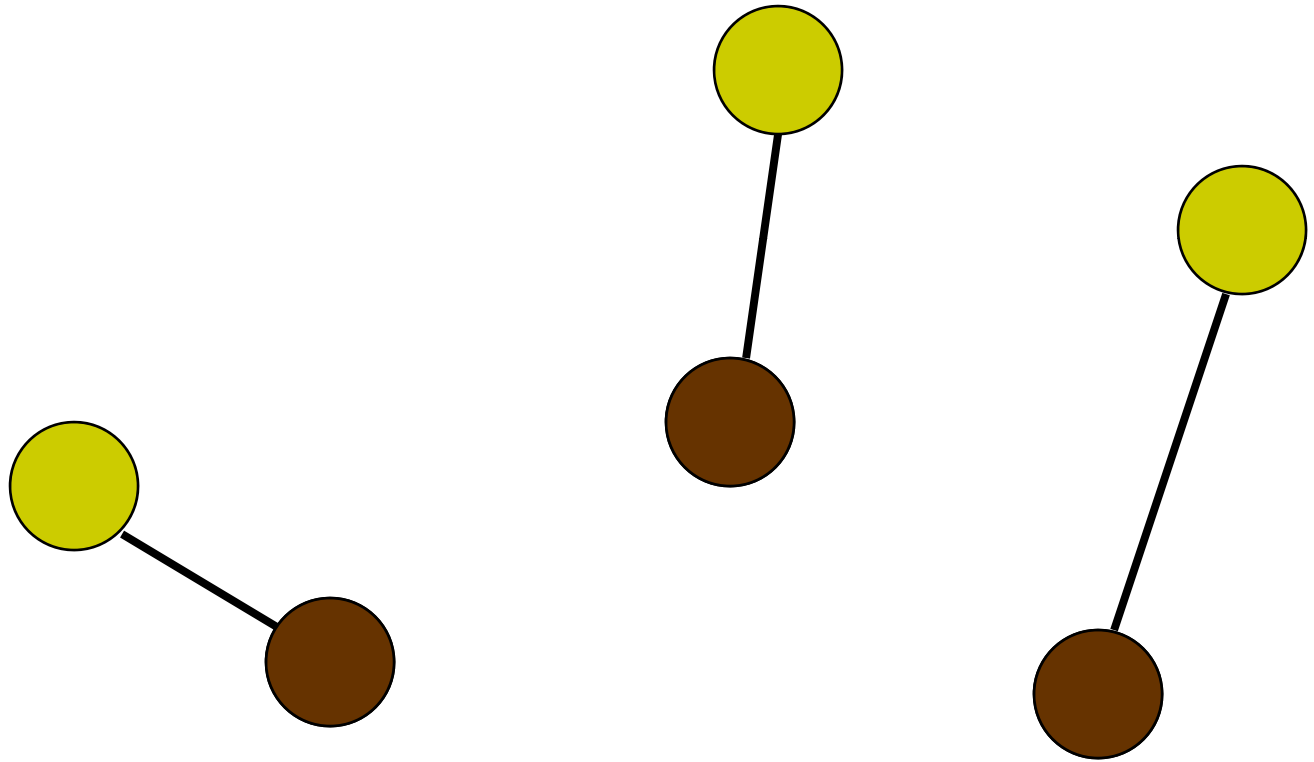

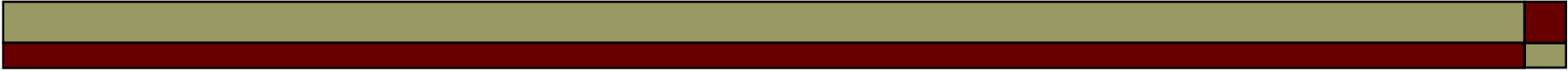

# Processes that give rise to non-independence of outcomes

---

- shared influence of context (common fate)
- people influence one another directly (mutual influence)
- people choose partners similar to themselves (assortative mating)



# When dependency is ignored

---

- Effect estimates are unbiased
- Standard errors are biased
  - Usually too small
  - Hypothesis tests too liberal



# Types of outcome variables

---

- These models assume that the members of the dyad are measured on the same outcome
- One aim is to use models to create dyadic measures
  - Discrepancy as an example
- May be interested in individual outcomes rather than dyadic property
  - Must take dependency into account

# Within-dyad variation in scores (discrepancy measured by slope of line)

---

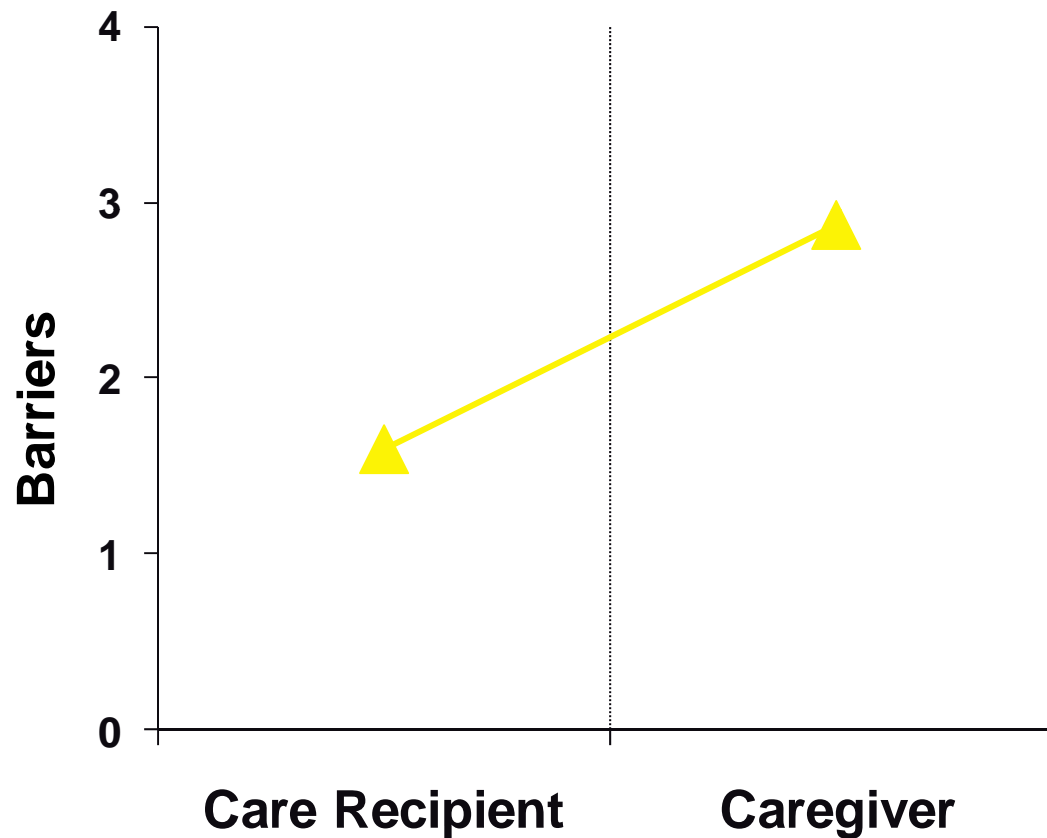

# Between-Dyad Variation in Discrepancy Slopes

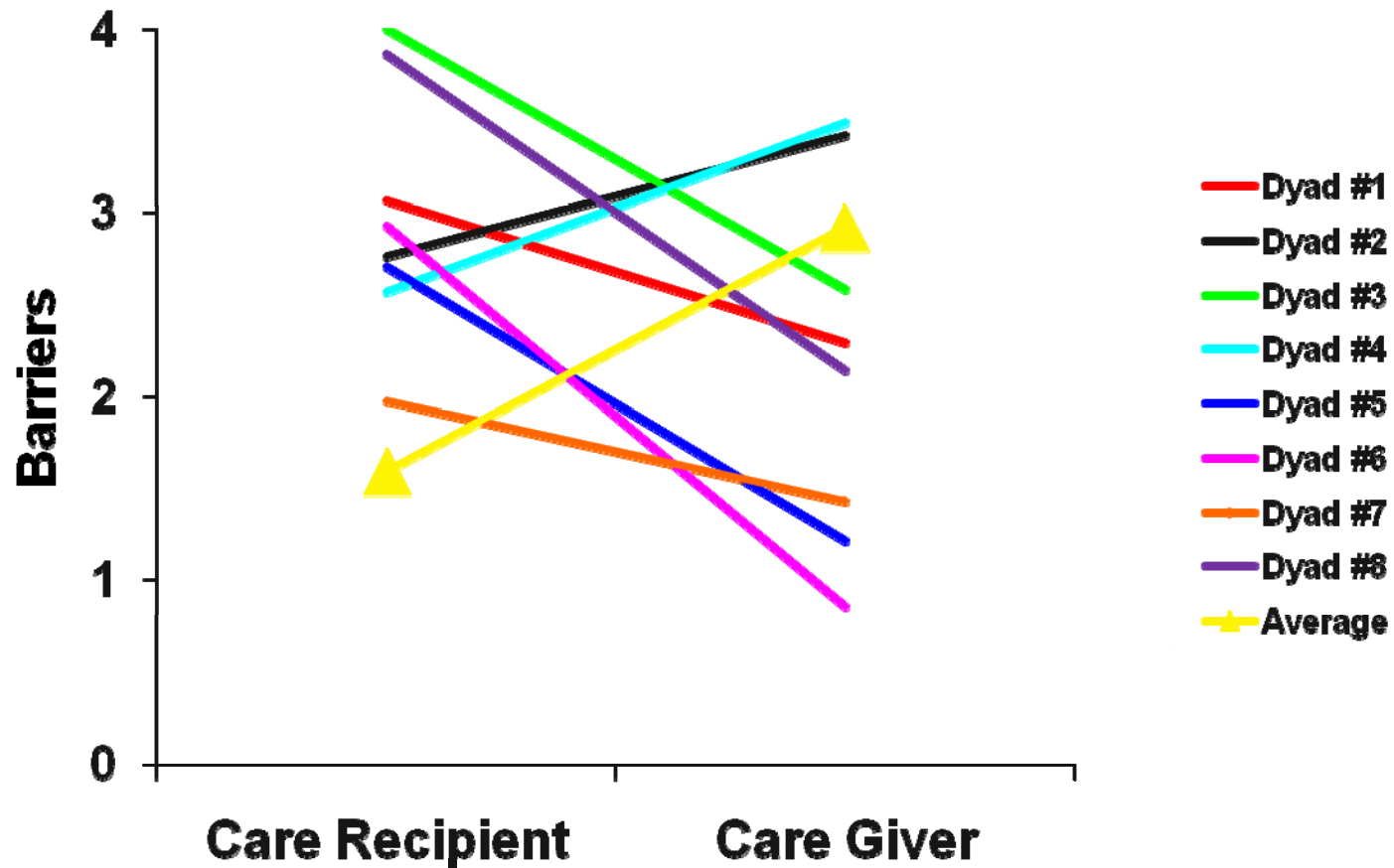



## 2 general types of dyads

---

- Distinguishable or Unexchangeable
  - Dyads with a categorical within-dyad variables that differentiates between members in a meaningful way
  - Heterosexual couples, therapist-client, mother-child , caregivers and care recipients
  
- Indistinguishable or Exchangeable
  - Ordering of the two members is arbitrary
  - Twins, friends, gay and lesbian couples

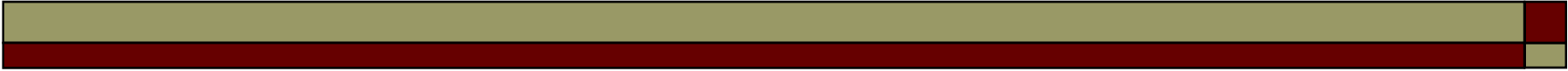

# Types of predictor variables for distinguishable dyads

---

## Between-Dyads

Both members have the same score,  $x = x'$   
e.g., length of relationship, dad's anxiety

## Within-Dyads

Sum of 2 scores a constant,  $X + X' = c$   
e.g., gender coded 0 & 1 = 1

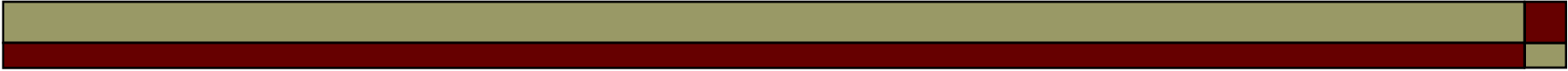

# What to do if the data are non-independent

---

Need a strategy that includes the dyad in the analysis

Change unit of analysis from person to dyad

- aggregate all variables to dyad level
- ignores two sources of variation

Multilevel Modeling – models hierarchy



# Multilevel Models

---

- Necessary for correct modeling of data with a nested structure (lower-level units nested in a higher level)
  - Students nested within classrooms
  - Occasions of measurement nested within the person
- Extension to dyads: key is to see responses of members of dyad as nested in the dyad
  - Work and marriage (Longitudinal dyads: Barnett, Raudenbush & Brennan, 1995)
  - Caregiving dyads (Discrepancy scores: Lyons & Sayer, 2002)

# Multilevel model for dyads

**Between-couple**

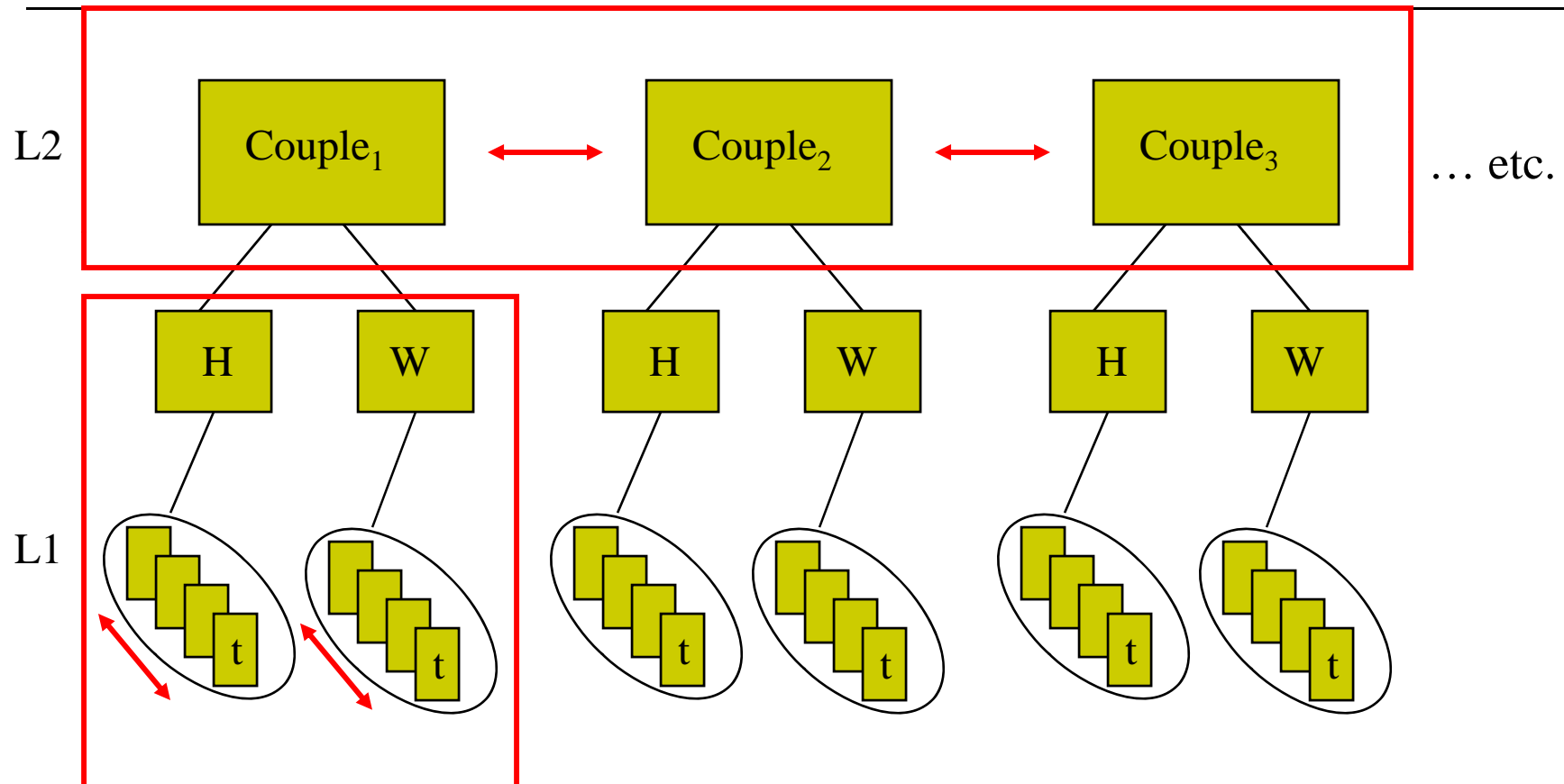

**Within-couple**



# Statistical benefits of MLM for dyadic analysis

---

- Accounts for non-independence by modeling the shared variance – leads to improved precision (unbiased se)
- Models both within-dyad and between-dyad differences
- Can use any combination of predictors with both shared and distinct values
- Allows for missing responses within-dyad
- Post-estimation measures of the dyad



# Conceptual benefits of MLM for dyadic analysis

---

Study What We Are Really Interested In  
Dyadic Properties such as discrepancy,  
similarity, reciprocity

Examine Mutual Influence in the Dyad  
Actor-Partner Interdependence Model  
allows for both within-person and cross-  
person effects  
Over-time Effects



# Overview of Presentations

---

- Aline Sayer: Introduction to dyadic analysis
  - Limitations of current methods
  - Advantages of multilevel models
- JuliAnna Smith: Basic multilevel models for dyads
  - Spouses across the transition to parenthood
- Jade Logan: Application of more advance models
  - Differences in parenting style (discrepancy scores)
  - Multiple reports of children's social skills (triadic outcome model)